

67.39.279.493**BPW Trailer Axle NHZFSLU 9010-15 EZ ECO MAXX**

Brake SN 3020 BPW 95

for ABS, with sensors

Track 1950 mm, spring seat centre 1100 mm, booster bracket centre 247 mm
(LU1)

for diaphragm cylinder, AGS ECO-Master, lever length (HL) 120 - 165 / 250

max. connection type 30, lever length (HL) 165

welded on booster brackets rear

Trailing arms 30 mm cranked, 1 x 51 / 100 mm, length 500 / 380 mm

with tracking plates

with hanger brackets execution E, height 268 mm

Shock absorber centre 858 mm front

without air bags

Brake drums 260 mm wide

Wheel connection 175.8 / 225 / 10

Wheel studs M 22 x 1.5

without wheel nuts

No.	Name	Code number	Dimension	Quantity
	BPW Trailer Axle NHZF 9010-15 ECO MAXX	24.38.502.113		1
1000	Trailing arm incl. item 1005	05.082.13.67.0	Ø 30, 30, 1 x 51 / 100, L1 500 / 380	2
1005	Bush	02.0316.90.00	Ø 30 / 57 x 102	2
1012	Locking plate incl. item 1015	05.348.30.05.0	L1 = 500 / B = 90 / H = 48 - 58	2
1015	Plug	03.379.00.27.0		4
1026	Spring pad	03.032.27.62.0	125 / 150 / 214 / 179 / 62 / Ø 72	2
1032	Spring plate, right	05.145.22.44.0	125 x 150	1
1033	Spring plate, left	05.145.22.43.0	125 x 150	1
1035	Spring pad for centering frame 03.295.46.20.0 / 03.295.46.21.0	03.032.21.53.0	95 / 150 / 192 / 125 / 43,5 / □ 73 x 98	2
1041	Tracking plate	05.281.36.15.0	235 x 98 x 5	2
1042	Tracking plate	05.281.36.20.0	218 x 98 x 5	2
1050	Spring U-bolt	03.138.44.08.4	M 24 / 102,5 / 125 x 280	4
1050	Spring U-bolt	03.138.44.16.4	M 24 / 102,5 / 125 x 292	4
1055	Washer	02.5401.25.07	A 25	8
1150	Repair kit spring pivot bolt bearing, rigid, FB 100 mm, M 30 x 2, straight steel hanger bracket, loose wearing plate item 1005, 1154, 1165, 1168, 1525, 1535	09.801.08.77.0	Torsion protection with square internal lock-bush, loose wearing plate, spring bolt M 30 x 2	2
1152	Spring bolt assembly, rigid, FB 100 mm, M 30, straight steel hanger bracket item 1154, 1165, 1168, 1525 replaced by 05.857.00.54.0	05.857.00.24.0	Torsion protection with square internal lock-bush, loose wearing plate, spring bolt M 30	2
1152	Spring bolt assembly, rigid, FB 100 mm, M 30 x 2, straight steel hanger bracket item 1154, 1165, 1168, 1525	05.857.00.54.0	Torsion protection with square internal lock-bush, loose wearing plate, spring bolt M 30 x 2	2
1154	Spring bolt Torsion protection with square internal lock-bush Model no longer available.	03.341.05.03.0	M 30 x 200 - 8.8 / Ø 52	2
1154	Spring bolt Torsion protection with square internal lock-bush	03.341.05.08.0	M 30 x 2 x 208 / Ø 52	2

67.39.279.493**BPW Trailer Axle NHZFSLU 9010-15 EZ ECO MAXX**

No.	Name	Code number	Dimension	Quantity
1165	Washer Torsion protection with square internal lock-bush, spring bolt M 30	03.320.32.38.0	Ø 31 / 57 x 5	2
1165	Washer	03.320.34.54.0	Ø 31 / 71 x 6	2
1168	Lock nut	03.260.15.01.0	M 30 / SW 46	2
1168	Lock nut	03.260.15.02.0	M 30 x 2 / SW 46	2
1300	Shock absorber incl. item 1303, 1304 Read off the code number from the shock absorber. Replace shock absorbers on an axle as a complete set.	02.3722.83.02	Ø 65 / 75, 326 / 496, 235 / 255	2
1302	Repair kit shock absorber bush item 1303, 1304	09.801.08.18.0		4
1303	Bush Only deliverable per kit 09.801.08.18.0 (item 1302)!	02.0314.39.00	Ø 24 / 32 x 55	4
1304	Rubber bump stop Only deliverable per kit 09.801.08.18.0 (item 1302)!	02.2805.10.00	Ø 23 / 50 x 25	4
1315	Hexagon screw upper shock absorber attachment with screw	03.340.14.12.0	M 24 x 275 - 8.8 / SW 36	2
1317	Sleeve	03.200.75.62.0	Ø 25 / 40 x 55	2
1330	Lock nut	02.5220.74.12	VM 24 - 10 H 24 / SW 36	10
1510	Hanger bracket, rigid, torsion protection with square internal lock-bush, loose wearing plate incl. item 1535	05.375.40.66.0	Ø 30 / 268 / 128 / 170 / 41 / 93,5 / 242	2
1525	Wearing plate (loose)	03.164.35.01.0	Ø 30,2 / 120 x 125 x 5	4
1535	Bush Torsion protection with square internal lock-bush, loose wearing plate	03.113.01.46.0	Ø 30,5 / 55 / 73,6 x 24	4

67.39.279.493

BPW Trailer Axle NHZFSLU 9010-15 EZ ECO MAXX

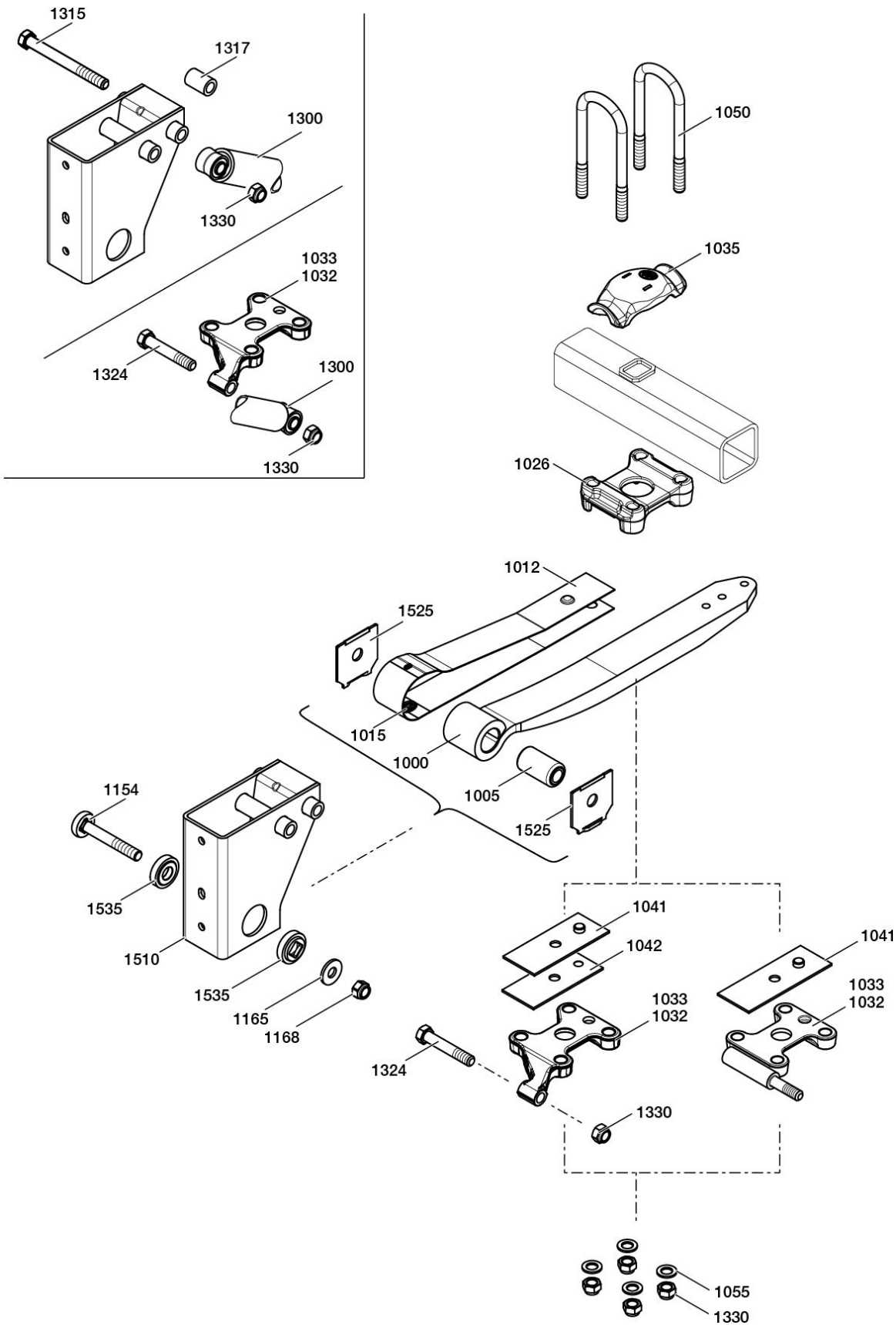

24.38.502.113

BPW Trailer Axle NHZF 9010-15 ECO MAXX



L (form closure (square))

Brake SN 3020 BPW 95

for ABS, with sensors

Track 1950 mm, spring seat centre 1100 mm, booster bracket centre 247 mm

for diaphragm cylinder, AGS ECO-Master, lever length (HL) 120 - 165 / 250

Brake cylinder max. type 30, lever length (HL) 165

welded on booster brackets rear

Brake drums 260 mm wide

Wheel connection 175.8 / 225 / 10

Wheel studs M 22 x 1.5

without wheel nuts

No.	Name	Code number	Dimension	Quantity
10	Axle beam assembly	11.11.111110	only upon request	1
23	Plate	03.281.42.03.0		1
25	Centering frame Replaced by 03.295.46.21.0. Note the modified shape of the spring pads!	03.295.46.20.0	72,5 x 60 x 12	2
25	Centering frame	03.295.46.21.0	72,5 x 60 x 8	2
28	Support bearing plate	03.285.54.16.0		2
190	Booster bracket	03.182.35.80.0		2
209	Repair kit low-maintenance brake camshaft bearing item 210, 214, 220, 221, 225, 227, 230, 232, 245, 271, 272	09.801.06.09.2	with 03.229.02.18.0 / 03.229.02.19.0, for brake camshaft with 3 or 4 as last digit of code number	1
210	Bush	03.112.44.34.0	Ø 42 / 46 x 72,6	2
214	Grease nipple	02.6802.03.50	AM 10 x 1	2
215	Cover	02.3505.20.00		6
220	Bearing box Bearing box attachment with 4 locking screws (introduced 09/97), brake camshaft with 0 - 2 as last digit of code number Model no longer available. Conversion kit: 09.801.06.09.1	03.229.02.16.1		2
220	Bearing box for brake camshaft with 3 or 4 as last digit of code number	03.229.02.18.0		2
221	Bearing box, for grease nipple for brake camshaft with 0 - 2 as last digit of code number Model no longer available. Conversion kit: 09.801.06.09.1	03.229.02.17.0		2
221	Bearing box, for grease nipple for brake camshaft with 3 or 4 as last digit of code number	03.229.02.19.0		2
225	Spherical bearing for brake camshaft with 0 - 2 as last digit of code number Model no longer available. Conversion kit: 09.801.06.09.1	03.113.14.03.0	Ø 42 / 62 x 38	2
225	Spherical bearing for brake camshaft with 3 or 4 as last digit of code number	03.113.14.04.0	Ø 42 / 60 x 38	2
227	Grease nipple	02.6802.14.50	AM 8 x 1	2
230	Screw assembly incl. item 232	05.865.00.02.0	M 8 x 30 - 8.8 / SW 13	8
232	Lock nut	02.5273.49.88	M 8 - 8 / SW 13	8
240	Brake camshaft	05.097.60.17.4	615,5 / 740	1
241	Brake camshaft	05.097.60.18.4	615,5 / 740	1

24.38.502.113

BPW Trailer Axle NHZF 9010-15 ECO MAXX



No.	Name	Code number	Dimension	Quantity
245	Assembly kit item 250 - 262, 268, 270, 274	09.801.08.86.0		2
250	Locking ring	02.5676.01.00	A 42 x 2,5	2
254	Ring	03.310.81.02.0	Ø 42,1 / 45,9 x 4	2
255	O-ring	02.5677.37.42	Ø 37 x 2.6 (black)	2
256	O-ring	02.5679.23.00	Ø 40 x 2.5 (green)	2
258	Sealing ring	03.120.42.02.0	Ø 42 / 56 x 2/4	2
260	Circlip for brake camshaft with 1 or 2 as last digit of code number Not included in 09.801.06.09.1.	02.5616.05.90	Ø 37 / 41 x 2	2
260	Bush for brake camshaft with 3 or 4 as last digit of code number	03.113.03.06.0	Ø 37,4 / 45 x 21,3	2
262	Washer	03.320.11.16.1	Ø 22,5 / 42 x 10,5	2
266	Lever (brake lining wear indicator)	03.190.14.07.1	85 mm	2
268	Lock nut	03.260.14.08.0	M 22 x 1,5 / H 15 / SW 32	2
270	Sealing ring	03.120.43.19.0	Ø 37 x 25	2
271	Sealing ring for brake camshaft with 3 or 4 as last digit of code number	03.120.42.09.0	Ø 42 x 15	2
271	Sealing ring for brake camshaft with 1 or 2 as last digit of code number Not included in 09.801.06.09.1.	03.120.43.12.0	Ø 41 x 20	2
272	Sealing ring for brake camshaft with 3 or 4 as last digit of code number	03.120.42.08.0	Ø 45 x 13,5	2
272	Sealing ring for brake camshaft with 1 or 2 as last digit of code number Not included in 09.801.06.09.1.	03.120.43.10.0	Ø 34 x 25,5	2
274	Circlip	03.350.30.02.0	Ø 49 x 9	2
279	Set of slack adjuster (ECO-Master) item 230, 232, 262, 266, 280, 285	05.574.82.87.3	Lever length (HL) 120 / 135 / 150 / 165 = Ø 14 / L 180 = Ø 11 / 250 = Ø 14	1
280	Slack adjuster (ECO-Master) incl. item 215, 283, 284	05.174.82.63.3	Lever length (HL) 120 / 135 / 150 / 165 = Ø 14 / L 180 = Ø 11 / 250 = Ø 14	2
283	Cap	03.211.90.15.0		2
284	Grease nipple	02.6850.01.02	AS 8 x 1	2
285	Shaped plate	03.165.25.28.0		2
295	Return spring	05.397.26.03.0	Ø 25,8 / 2,8 x 148 (185)	2
325	'C' Clip for brake with splitted roller	03.188.02.02.0	33 / 32,5 x 10	8
328	Repair kit brake SN 3020, with brake shoes item 329, 330	09.801.02.42.0	for brake with splitted roller	1
329	Repair kit brake SN 3015 / 3020, without brake shoes item 315, 325, 363, 364, 367, 368	09.801.02.47.0		1
330	Brake shoe assembly, with lining item 335, 350, 357	05.091.14.77.1	SN 3020	4

24.38.502.113 BPW Trailer Axle NHZF 9010-15 ECO MAXX



No.	Name	Code number	Dimension	Quantity
335	Brake shoe assembly, without lining incl. item 345 - 348	05.091.14.80.0	SN 3020	4
344	Repair kit brake shoe roller item 345 - 348	09.801.02.91.0	for brake with splitted roller	2
345	Roller	05.331.44.02.0	Ø 26 / 45 x 33,5	4
346	Bolt	03.084.75.24.0	Ø 26 x 58,5	4
348	Ring	03.310.70.15.0	Ø 24 / 31 x 3,5	8
350	Brake lining	03.092.14.45.0	18 mm	8
357	Rivet	02.5805.80.35	B 8 x 15	64
363	Return spring	05.397.34.17.0	Ø 20 / 3,6 x 180 (197)	4
367	Return spring (hook)	03.397.33.08.0	Ø 19 / 3,6 x 36 (40)	2
368	Return spring (eye)	03.397.33.09.0	Ø 19 / 3,6 x 36 (40)	2
380	Brake drum	03.109.46.07.0	Ø 300 x 200 / 260 / 190 / 10 x Ø 23 / 225 / 3 x 45°	2
418	Repair kit roller bearings with axle nut and hub cap item 420, 423, 428 - 431, 437, 438, 440, 441, 445 - 448, 460	09.801.02.33.0	with hub cap 03.212.24.25.0	2
419	Repair kit roller bearings without axle nut and hub cap item 420, 423, 428, 430, 431, 440, 441, 445	09.801.02.72.0		2
420	Thrust ring cpl. item 421, 422, 424	05.370.07.67.0		2
421	Thrust ring	03.370.07.60.0	Ø 86 / 115 / 139 x 22	2
422	Thrust ring	02.5664.57.00	Ø 115 / 137 x 10,5	2
423	Ring	02.5683.62.00	Ø 131 / 140 x 12	2
424	O-ring	02.5677.90.40	Ø 90 x 3	2
428	Dirt seal	02.5681.98.00	Ø 103 / 147 x 15	2
430	Roller bearing	02.6410.24.00	33116	2
431	Dust cover (oil catcher)	03.010.93.33.0	Ø 84 / 129 x 8,5	2
434	Repair kit hub bearing (cpl. hub) item 420 - 449, 460, 560	09.801.06.54.0	with hub 03.272.27.48.0	2
435	Hub	03.272.27.48.0	M 125 x 2 / Ø 110/130 / 175,5 / 10 x Ø 22 / 225	2
437	Locking ring	02.5606.40.90	Ø 140 x 4	2
438	Locking ring	02.5606.12.90	Ø 112 x 4	2
440	Thrust ring	03.370.25.16.0	Ø 54 / 98 x 9	2
441	Roller bearing	02.6410.25.00	32310	2
445	Washer	03.320.73.13.0	Ø 43 / 61 x 5,8	2
446	Axle nut	03.266.46.02.0	M 42 x 2 / Ø 110 / SW 65	2
447	Bolt	03.084.71.17.0	Ø 8 x 45	2
448	Hooked spring ring	03.188.03.06.0	Ø 54 x 2	2
460	Hub cap	03.212.24.25.0	M 125 x 2 / H 61 / SW 110 / BPW	2
472	Wheel stud (helical fit wheel stud)	03.296.33.12.1	M 22 x 1,5 / 97 / 62	20

24.38.502.113**BPW Trailer Axle NHZF 9010-15 ECO MAXX**

No.	Name	Code number	Dimension	Quantity
500	Set of dust cover assemblies item 501 - 504, 510, 513, 520	99.00.000.1.09	SN 3020 / □ 120 / 0°	1
501	Dust cover	03.010.99.87.0	Dust covers available as sets (upper + lower)	1
502	Dust cover	03.010.99.88.0	Dust covers available as sets (upper + lower)	1
503	Dust cover	03.010.99.85.0	Dust covers available as sets (upper + lower)	1
504	Dust cover	03.010.99.86.0	Dust covers available as sets (upper + lower)	1
510	Collar screw	02.5071.55.80	M 10 x 15 - 8.8 / SW 13	8
513	Sealing ring	02.5681.78.00	Ø 6 / 10 / 13 x 7	2
520	Plug	03.379.00.23.0		4
540	Adapter plate	03.189.11.77.0		2
542	Sensor bracket	03.189.07.87.0	H = 12,5	2
550	Tapping screw	03.341.00.05.0	M 8 x 22 - 10.9 / Torx Plus 40IP	4
551	Cylinder head screw	02.5015.00.80	M 6 x 16 - 8.8 / SW 5	4
553	Spring washer	02.5601.06.90	A 6	4
560	Exciter ring	03.310.08.18.0	Ø 152 / 170 x 15 (80 Z)	2
564	Clamp	02.3507.32.00		2
565	Drive pin	02.6005.25.40	Ø 4 x 10	2
570	Sensor	02.3317.05.00		2
571	Bush for ABS	02.0316.59.00	Ø 16 / 18,4 x 31,5	2
585	Support	03.189.07.72.0		2
586	Retaining clip	02.1421.11.00		2
587	Serrated lock washer	02.5414.11.90	A 10,5	2
900	Special grease for ABS-sensors	02.1040.17.00		1

24.38.502.113 BPW Trailer Axle NHZF 9010-15 ECO MAXX

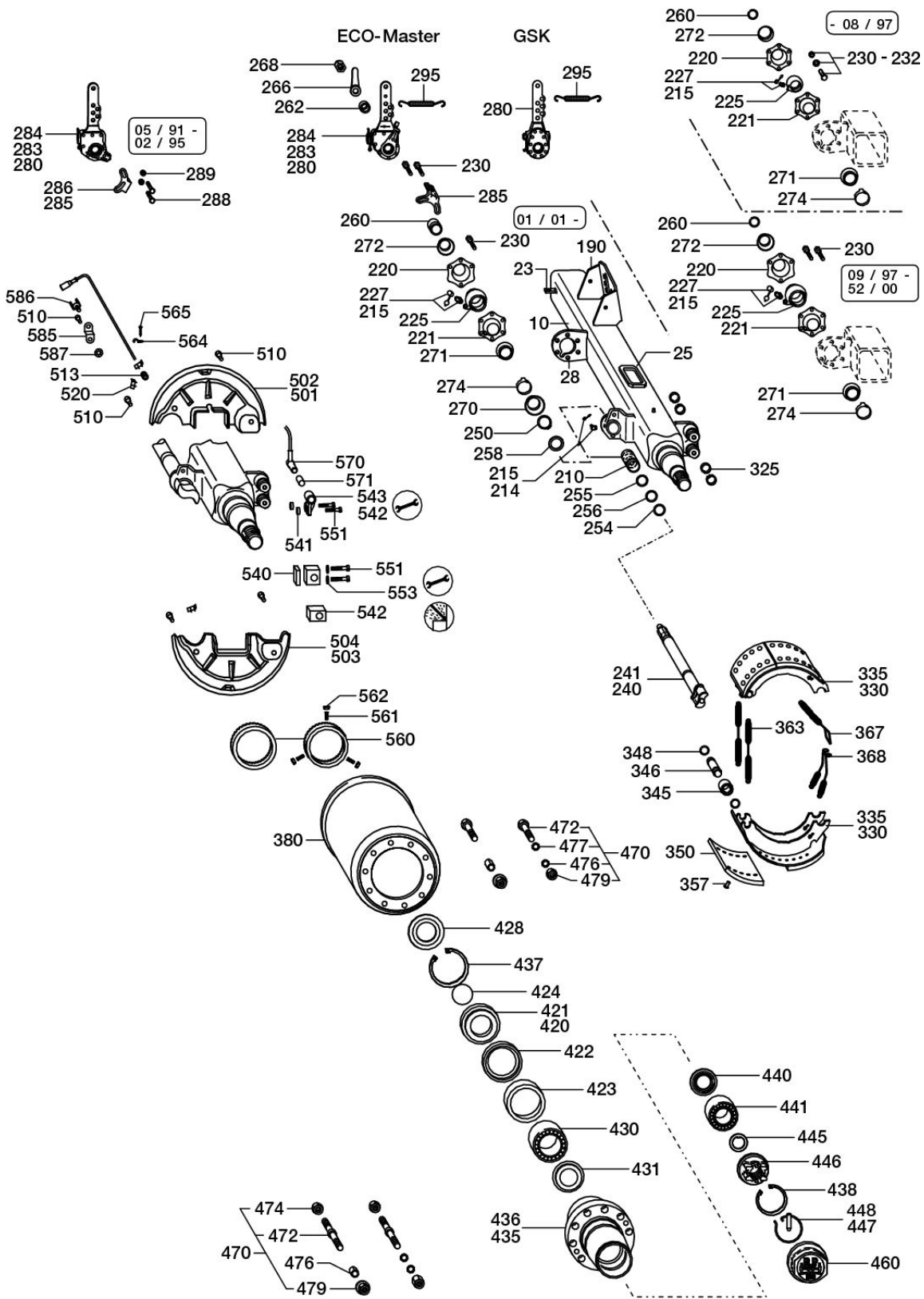

24.38.502.113 BPW Trailer Axle NHZF 9010-15 ECO MAXX



-2015 **AGS**

230	05.865.00.02.0	M 8 x 25 - 8.8 / SW 13
231	02.5403.08.92	B 8
232	02.5202.12.82	M 8 / SW 13
288	02.5025.30.82	M 8 x 25 - 8.8 / SW 13
289	02.5273.32.82	M 8 - 8 / SW 13

2016- **AGS**

230	05.865.00.02.0	M 8 x 30 - 8.8 / SW 13
232	02.5273.49.88	M 8 / SW 13

-2015 **GSK**

230	05.865.00.02.0	M 8 x 25 - 8.8 / SW 13
231	02.5403.08.92	B 8
232	02.5202.12.82	M 8 / SW 13

2016- **GSK**

230	05.865.00.02.0	M 8 x 30 - 8.8 / SW 13
232	02.5273.49.88	M 8 / SW 13